

“The Headliner”

Newsletter of the Northern Ohio Regional Group #20
Early Ford V-8 Club of America
Celebrating 45 Years 1969 ~ 2014



Volume 21 Number 1

January 2014

Mission Statement: “To preserve and authentically maintain vehicles manufactured by the Ford Motor Company for the model years 1932 through 1953 inclusive, and to serve as an accurate and technical source of information concerning these automobiles for the benefit of its members as well as the general public.”

Message From Our President

Too cold to go to the garage and putter, but the to do list keeps getting bigger. Just day dreaming about getting in the old Merc. and cruising down the road. Going no place in particular and maybe a stop for some ice cream.



Then Georgene woke me up and told me I need to shovel some snow. By the time you get this we had a board meeting and results will be forthcoming. By attending our monthly meeting we can share additional information and ideas on activities and events. We need everyone's input so we can decide and plan dates. I would like nothing better than each one of us could host an event, even if it's a short Sunday ride and an ice cream stop. There are many things to do.

Make sure that your dues are in as Craig can get a start on the new roster. I'm looking forward to the first meeting and break the ice. I'm open for comments, criticism, and above all suggestions.

Georgene and I hope everyone has a Happy, Healthy and Safe New Year.

Drive ur V8 B4 it's 2 L8. Hank put wheels on them for a reason

Jeep

Officers & Board 2013

President: Jeep Iacobucci
Vice President: Craig Gorris
Secretary: Virginia Herrmann
Treasurer: Ann Davis

Directors

Neal Garland
Annette Gorris
Richard Jandrey
Mike Wisniewski

All Meetings are held at
Stow Community Center
3800 Graham Road
Stow, OH

“Kick Tires”: 7:00
Meeting Begins: 7:30
Ends: 10:00 or Sooner

Website:

www.norgv8club.org

Editor

Annette & Craig Gorris
10160 Echo Hill Drive
Brecksville OH 44141
440-526-6138
annette.gorris@gmail.com

Happy 45th Anniversary NORG
1969 ~ 2014

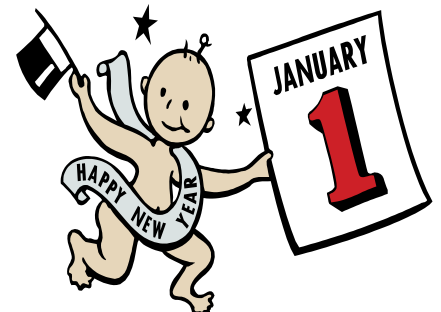

Happy 45th Birthday NORG

NORG celebrates 45 years this year. We will provide historical information as well as early photos in this newsletter throughout 2014 for your enjoyment.

A Brief History Of The Northern Ohio Regional Group, (#20) Early Ford V-8 Club of America

The inception of the Northern Ohio Regional Group (NORG) began as a meeting between a fellow named Bob Jones who began talking to another fellow Ken Canankamp. They met at a Swap Meet in Randolph Ohio in early 1967. Bob Jones had lived in Southern Ohio but moved North to find work in the Akron area. Bob had belonged to the Southern Ohio Group of the Early Ford V-8 Club of America. This group, which has since broken up, was known as the RG #2, Ohio Regional Group, with a mailing address in Newark, Ohio.

Both Bob and Ken were members of the National Club but without a regional affiliation.

As events unfolded, Bob and Ken discussed forming a Regional Group. Bob knew a number of fellows with early (1932-1940) Ford V-8's and sent postcards to them asking if they had any interest in forming a Regional Group. As a result, significant interest was generated resulting in a number of these fellows getting together which provided the genesis of N.O.R.G.



The club was officially formed in 1968 and chartered by the National Early Ford V-8 Club of America as Regional group #20. The first officers included President Gene Baumburger, who served during 1968, Vice President, Ray Moore, Treasurer Joe Sirgo, Secretary, Annette Kittle, and newsletter editor Tom Crites. A note of interest, the Club Newsletter was originally titled "The Greyhound" and some-time later was changed to "The Headliner".

According to the Club accounts, our Regional Group, as we know it, was registered as Regional Group #20, as recorded in the 1969 September/October issue of the V-8 Times. Early club records did not accurately track Regional Group numbers. However the 1970 May/June issue of the V-8 Times suggests that the Ohio Regional Group was #20. This was determined by counting the total number of Regional Groups beginning with #1, the Golden Gate Regional Group. The Northern Ohio Regional Group was #21 on that same list. However after the Ohio Regional Group broke up, N.O.R.G became #20. The first address was Paris, Ohio 44469.

The early members included Bob Jones, *Ken Canankamp, Gene Baumburger, Eddie Black, George and Paul Fabick, Jerry Firl, *Elton (Sonny) Hunt, Ray Moore, *Bill Royer, Jack Pratt, Paul Barnhart, Tom Crites, Rick Dahlman, Gary Kittle, Jim Miller, Stan Perenkovich, Joe Sirgo

(* members today)

The second President was Bob Jones who served in 1969 followed by Ken Canankamp who served from 1970 until 1977. Ken and Bill Royer have the distinction of being continuous members since the club's inception in 1968. The first meetings were held in member's homes. Later we met in a room behind our small post office in Berlin, Ohio. When Ken was President, he was in charge of a large number of apartment complexes for a large company in the area. As a result, the club would meet in the clubrooms at these facilities. One member owned a funeral Parlor and we even met there on occasion. As with any group, members came and left however there were about seven or eight couples who managed to provide the dependability that was necessary to keep the club together.

After seven years as President, Ken was looking to pass the torch so as to instill new ideas and "new blood" into the club. About this same time John Coleman took a keen interest and volunteered to run for President. John held the office for the next two years and during this time the club experienced a "second wind" which has kept the club successful into this millennium.

N.O.R.G. has remained very active both as a Charter member of the Early Ford V-8 Club of America as well as a local car club. Not only has it hosted two Eastern National Early Ford V-8 Club Meets, but it publishes a monthly newsletter, The Headliner, and annual membership Roster. The Club also provides a variety of interesting social programs for its members as well as supporting the less fortunate through an annual charitable donation. Today N.O.R.G. consists of over 100 members and more than 80 early Ford V-8's and other vehicles. It is an active, exciting and energetic organization consisting of people who have fun working together and helping one another.

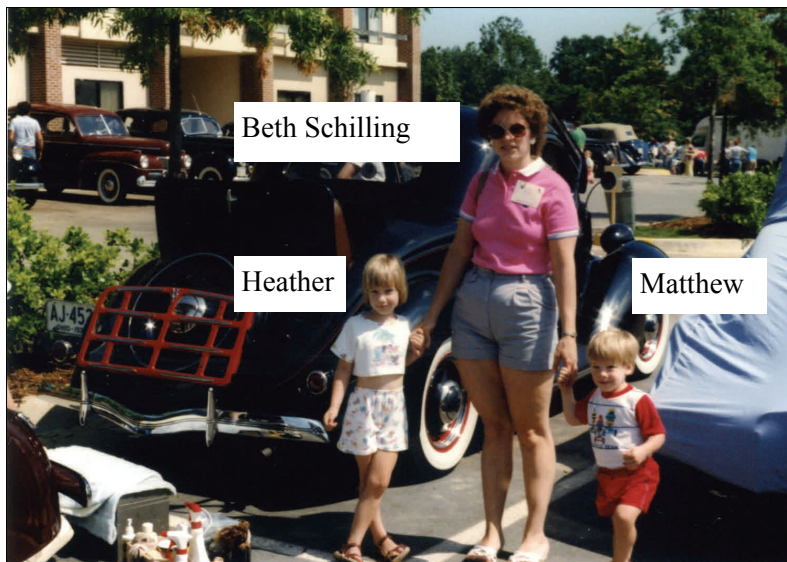
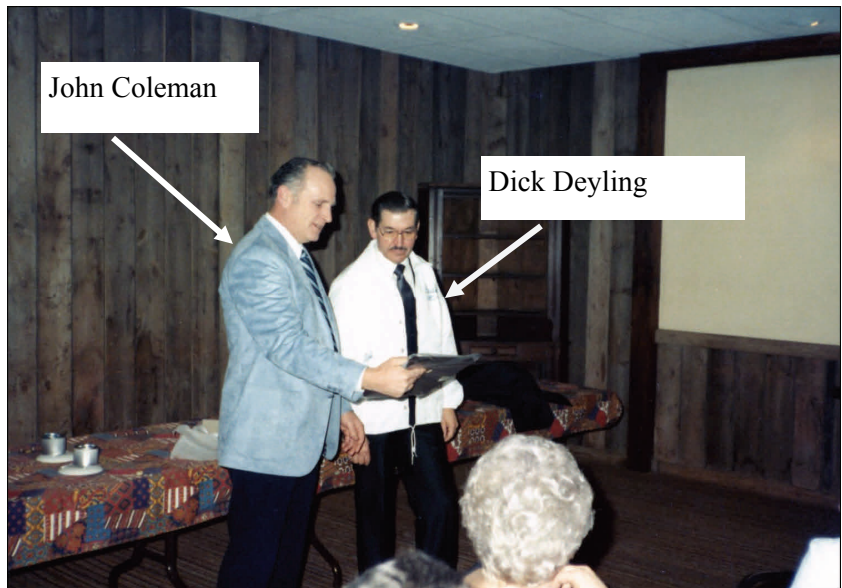

**Northern Ohio Regional Group #20
Past Presidents**

- Neal Garland 2009 – 2011
- Foster Buchtel 2007 – 2008
- Regis Schilling 2005 – 2006
- Barb Soltis 2003 - 2004
- Jim Bates 2001 – 2002
- Ron Wertz 1999 – 2000
- Jeep Iacobucci 1997 – 1998
- Craig Gorris 1995 – 1996
- Dave Duda 1993 – 1994
- Paul Eippert 1991 – 1992
- Ruth Canankamp 1989 – 1990
- Herb Strauss 1987 – 1988
- Barb Jordan 1984 – 1986
- Dick Deyling 1982 – 1983
- Don McKovich 1980 – 1981
- John Coleman 1978 – 1979
- Ken Canankamp 1970 – 1977
- Bob Jones 1969
- Gene Baumberger 1968

2014 Activities At A Glance

Tuesday & Wednesday February 18th & 19th National Board of Directors “face to face” meeting at Double Tree Hotel in Orlando Fl. ALL Members welcome.

Friday February 21st Monthly Business Meeting at Stow City Center

Monday thru Thursday June 23rd ~ 26th Eastern National Meet, Gettysburg PA

Tuesday thru Friday August 19th ~ 22nd Central National Meet, Springfield IL



Cookie Bakers

February: Momoe Garland

August: Sharon Bukszar

March:~ Beth Schilling

September: ~ ?????????

April: Good Friday No Meeting

October: ~ Ginger Posar

May:~ Virginia Herrmann

November: Liz Wisniewski

June: Bruce Lewicki

NORG DUES are DUE

Please return the form on page 11 with your \$25.00 Check

2014 is the 75th Anniversary of the 1939 Ford. We hope you like the following interesting technical information and historical facts about this model and contemporary world events.

Firsts

- First Fords with hydraulic brakes
- Wide-spaced headlights located in the fenders instead of between the fenders and hood on De Luxe models
- The entire hood assembly on the De Luxe raises, eliminating “hood sides” and louvers
- Engine fan is mounted directly on the crankshaft

Lasts

- Last year for mahogany-grained dashboards
- Last year for floor-mounted gearshift
- Last year for the convertible sedan

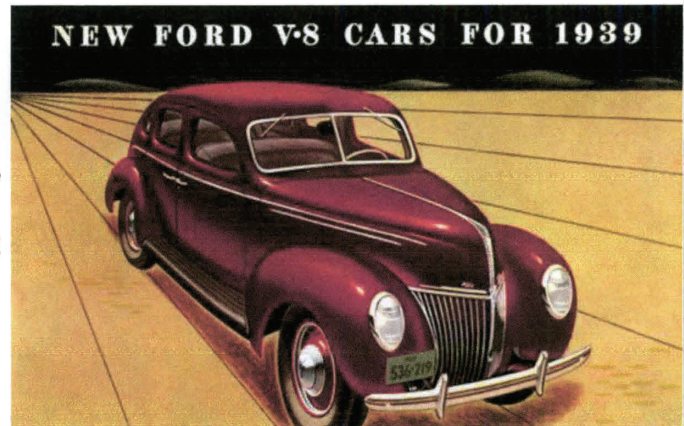

Technical Specifications

- Price – from \$599 for the 60 hp Ford V-8 Coupe to \$900 for the De Luxe Convertible Sedan
- Most expensive accessory – “Rotomatic” control radio at about \$45
- Weight – ranged from 2,463 lbs for the 60 hp Ford V-8 Coupe to 3,080 lbs for the V-8 wagon
- Engines – 221 cubic inch Flathead V-8 rated at 85 horsepower and 136 ci 60-hp Flathead V-8
- Production totals – 532,152; Fewest - De Luxe Convertible Sedan, 2,703; Most - Ford V-8 Tudor Sedan, 124,866
- Serial numbers – 85 hp: Beginning – 18-4,657,660 End – 18-5,210,700

Notable

- Ford introduced the new models November 4, 1938
- Ford dropped the term “Standard” for the base models, using the terms Ford V-8 and De Luxe Ford V-8
- On February 18, the Golden Gate International Exposition opened in San Francisco
- The New York World’s Fair opened April 30
- John Steinbeck’s *The Grapes of Wrath* is published April 14
- First Little League baseball game played June 6
- July 4 Lou Gehrig gives his last public speech
- *The Wizard of Oz* premieres at Grauman’s Chinese Theater August 15
- On September 1, WWII begins with Hitler’s invasion of Poland
- *Gone with the Wind* premieres in Atlanta December 13

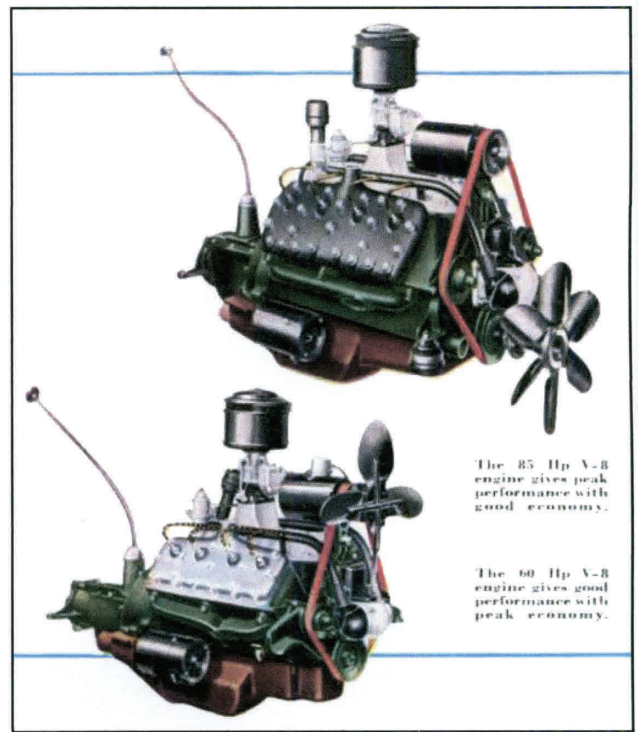

Thanks to the NIRG Road Chatter

Summary of the November 16 Conference Call Meeting of the Early Ford V-8 Club National Board of Directors

National Director Election: Thank you to all members who sent in your ballots. Southeast Director Wayne Deitrich and Midwest Director Ken Bounds have been re-elected to a second three-year term. The Board is pleased to welcome Mark Strohecker of California as our new California/Southwest Director, replacing Don Singleterry. Mark should be a great addition to the Board after being the co-chair of the very successful Golden Jubilee Grand National Meet. We also welcome Ewan Gardiner as International Representative for New Zealand, replacing Bob Woodford who served in that position for 21 years!

National Officers

The end of 2013 marks the end of Ken Bounds two years as your National President. At the Board meeting the new officer team for 2014 was announced. **Steve Lemmons** from Washington State has been elected to serve as your new **National President**, **Tom Johnston** of California was elected to the position of **Vice President** and **Joyce Parsons** of Texas was elected as **Secretary**. Congratulations to all.

Technical Books: Progress continues on the '40 Ford book, the '49-'51 Mercury book, and the Flathead Engine book. We hope to have the '40 book completed by the 75th Anniversary of that model in 2015. Significant steps have been recently taken on the plan to reprint the '40-'41 Ford pickup reference book written by Howard Towne in the late '70s. The new 50th Anniversary of Early Ford V-8 Club is now available for shipping. The book is the Henry Dominguez authored collectible book "*The Early Ford V-8 Club of America – Golden Jubilee*" celebrating the first 50 years of our Club. This 340-page, limited edition, hardbound volume is a must-have for any V-8 Club member. It chronicles the Club from its founding in 1963 right through the Golden Jubilee Grand National Meet. You can purchase the book online at www.earlyfordv8.org, by calling the Rasmussens at (707)226-5256, or by e-mail at v8accessories@gmail.com. Those who have already received the book say it is well worth the price of only \$29.95 plus shipping.

National Meets: The Club hopes that members plan to attend one (or more) of the three National Meets in 2014. The **Eastern National Meet** will be in **Gettysburg, PA, June 23-26**, the **Central National Meet** in **Springfield, IL, August 19-22**, and the **Western National Meet** in **Thousand Oaks, CA, September 2-5**. Information and registration for all three meets is available on the V-8 Club website, www.earlyfordv8.org. More information will be in the January-February issue of the V-8 Times.

At this time, no Regional Groups have stepped forward to host a National Meet in 2015. The Board has requested that Regional Groups give some consideration to hosting a meet in their area. The process can be very rewarding. Please contact your National Director, Lynn Stringer, if you would like more information about hosting a meet.

National Tour Program: The Albuquerque Group's National Tour in October was a success! We encourage all Regional Groups to consider running a National Tour in upcoming years. This is a great way to get our Early V-8s out on the road and exposed to the public. Please contact your National Director, Lynn Stringer if you would like more information about conducting a National Tour.

75th Anniversary Program: The 75th Anniversary Program will continue next year, celebrating the 75th Anniversary of the 1939 Ford and Mercury. Collectible license plate tabs have been created and will be presented to members showing these vehicles at a National Meet or driving them on a National Tour in 2014.

Judging Standards Committee: At the meeting I reported the results of recent decisions by the Judging Standards Committee. The Committee re-affirmed the decision to not require a point deduction for reproduction steel bodies. The Committee also formalized the rule that dropped axles are allowed on Touring A vehicles. *Finally, in a close decision the Committee decided to **not change** the rule requiring a 5-point deduction on judged vehicles for an added electric fuel pump.*

Finances: The Board is in the process of revising the Club's By-Laws to establish a staff position of Treasurer; Long-time club member Dave Rehor has been appointed interim Treasurer. In recent months the Club's CPA firm has completed a review of the books and has filed all applicable tax returns.

2014 Face-to-Face Board Meeting: Next year's face-to-face meeting will be held February 18-19 in Orlando, Florida. This meeting is open to all members. Please let me know if you would like to attend the meeting.

Officer Updates: As soon as a Regional Group has selected officers for 2014, please complete the annual update form and return it to your National Director, but no later than January 31. This information is important to make sure we have correct contact information for your group in the annual roster and on the National website. A fill-in form is available at www.earlyfordv8.org.



Thanks to Frank Scheidt Greyhound Express RG#3

Fuel Problems? Is it really today's gas...or something else?

I replaced the flexible fuel line (18-9288) from the gas line to the fuel pump in response to all the talk about ethanol ruining old flex hoses. A friend did the same thing but could only get the new fuel line nut and ferrel to screw into the new flex line one turn or so, then it stripped when he tried tightening it.

In looking everything over, here's what I discovered:

Fig.1: Pieces tested: 1/4" rubber fuel hose, old line nut, new line nut, new hose cut to show inside diameter, ferrel, new flex line, an older flex line.

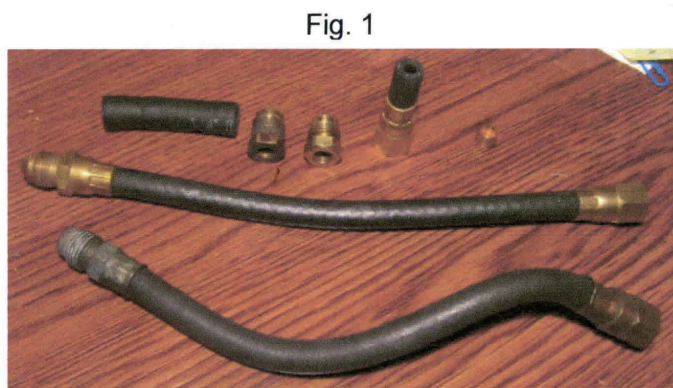

Figure 2: Left - Older flex hose fitting - note the size of the hole in the fitting. 4.70 mm;
Right - New flex hose fitting - note the drastic reduction in the hole size. 2.90 mm (40% smaller)

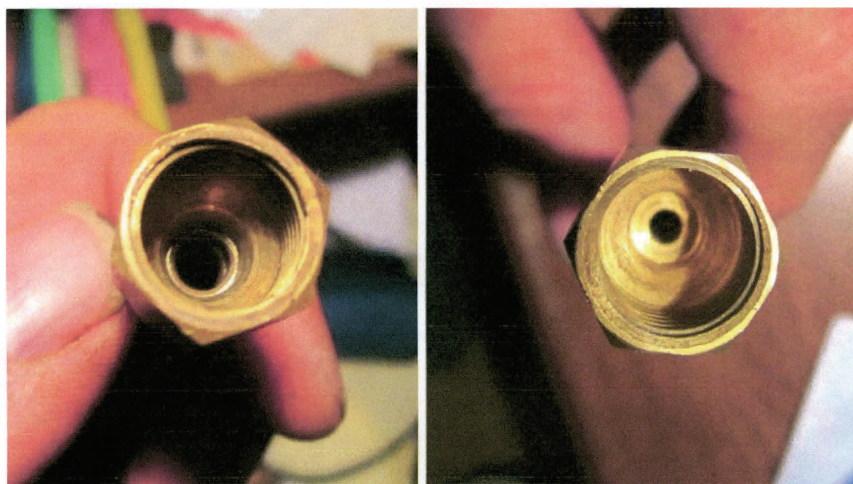

Figure 3: top - 1/4" fuel hose - inside diameter of the hose is 6.35 mm (1/4")
Bottom - Inside diameter of New flex hose is 4.45 mm (30% smaller)

It's too difficult to see or photograph the difference between the fitting on the old vs new flex hose, but the difference must be enough that prevents the line nut with ferrel from tightening properly. You can only get the first thread to turn in and any further tightening strips the nut. There's no problem with an older nut and hose.

So, what's going on here? My theory is that the foreign-made stuff is done metrically, as close to our fractional system as they can get, and sometimes "close enough" is NOT close enough! Either that or a system of quality control is sorely missing and bad parts out of tolerance are passed on through to our parts vendors, and eventually to us.

Is it really the fault of today's gas then, or is it that we're trying to suck fuel through a much too small orifice near the end of its travel all the way from the gas tank? I'm pretty sure, as many folks are, that the gas is a major factor. But maybe, just maybe, some of the parts we're using are adding to the problem. What do *you* think?

Send me YOUR experiences with these old Fords and today's replacement parts. Email me at 40ford@frontiernet.net



Fig. 3

NORG Past Activities



Front Row L-R

Ron Wertz
Everett Jordan
Jewell Thomas
Jim Kroll
Don Kraus

Back Row L-R

Craig Gorris
Herb Strauss
Ken Canankamp
Jim Bates
Jim Stewart
Bill Marx

National Award Winners, Fairfax VA 1988



Bill Cassidy June 1988

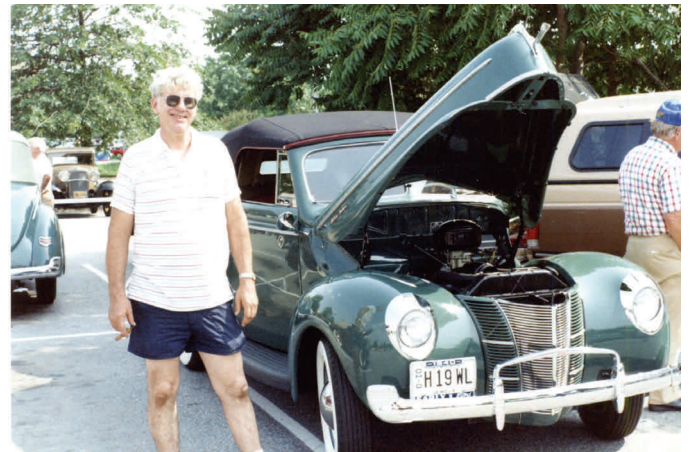

Herb Strauss June 1988



Jim Bates, Paul Eippert June 1988



Ken & Ruth Canankamp, Charlotte 1990

THE NIFTY FIFTIES
of Northern Ohio, Inc.

WOULD LIKE TO ANNOUNCE THE 27th Annual

All-Makes Cars & Trucks

2014 SWAP MEET

at

AutoNation Ford

Westlake

23775 CENTER RIDGE RD., WESTLAKE, OHIO

Formerly **John Lance** 

SUNDAY, JANUARY 26th

8:00 AM - 1:00 PM

Admission - \$4.00, (early birds - 7 AM) \$5.00

Food & Refreshments Will Be Available

76 INDOOR SPACES

PLENTY OF
UP-CLOSE PARKING!

10'x10' Vendor Space - \$10.00

Vendor Set-Up: Sat. 4-6PM & Sun. 6-8AM

FOR INFORMATION PLEASE CALL:

Frank @ 330-467-0465

Denny @ 330-571-3594

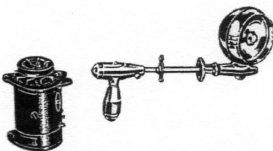

SEND CHECK OR MONEY ORDER TO:

NIFTY FIFTIES OF NORTHERN OHIO

7871 Eileen Drive

Macedonia, OH 44056



PLEASE RETURN THIS PORTION ALONG WITH CHECK OR MONEY ORDER

NAME: _____

ADDRESS: _____

CITY: _____ STATE: _____ ZIP: _____

PHONE: _____ Email: _____

OF SPACES: _____

**Northern Ohio Regional Group 20
Early Ford V8 Club of America
Membership Form
Annual Dues \$25.00**

**Year
2014**

Date: _____ National Number: _____ *If Info Same as 2013 Mark Same*

Name _____ Spouse _____

Address _____

City, State, Zip _____

Phone Number _____ Cell Phone Number _____

E Mail Address _____ Newsletter by E Mail Y ___ N ___

Fax _____

BIRTHDAY, MONTH & DAY: Self _____ Spouse _____

Winter Address _____ From _____ To _____

City, State, Zip _____

Phone Number _____ Newsletter sent to: winter address or E Mail? Circle One.

List all Early Fords you own from 1932 to 1953 and Highest Award won at a National Meet:

YEAR	MAKE	MODEL	AWARD
_____	_____	_____	_____
_____	_____	_____	_____
_____	_____	_____	_____
_____	_____	_____	_____

Make Check Payable to: N.O.R.G.

MAIL TO:

**Craig Gorris
10160 Echo Hill Dr.
Brecksville, OH 44141**





Early Ford V-8 Club of America
Northern Ohio Regional Group #20
P.O. Box 1074
Cuyahoga Falls, Ohio 44223

First Class Mail

Happy January Birthday

- Regis Schilling 01/03
- Foster Buchtel 01/09
- Rags Stallard 01/14
- John Schigulinsky 01/14
- Craig Gorris 01/17
- Morrie Dannenhirsh 01/21
- Mike Wisniewski 01/29
- Sandy Coulter 01/30



February MEETING :
Friday, February 21st
Stow City Center

The Headliner Deadline

1st Day of each month. Please e-mail articles, tech tips, outings, adds, club news and pictures to:

Annette Gorris

Don't Forget to Check out our updated website :

www.norgv8club.org

Parts Wanted—1936 5 Window Ford Coupe

Metal Piece That Fits Above Windshield and supports the Visors and covers Wiper Motor

Joe: Cell: 330- 603-9668

Home: 330-677-080

1935-1940 Ford Re-buildable Right Front Shock

Need to rebuild one for my truck

Dan Francis: Cell 330-931-0252

Home: 330-541-2133